

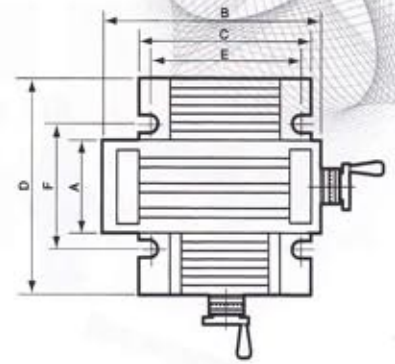

VCT-407



VCT-514



- Material: over FC-30
- Precision: 0.02/100mm
- Feature: The sliding surfaces are treated by heat-treatment & precision ground
- Can be used as measurement table

Specifications

Unit:mm

ORDER NO.	A	B	C	D	E	F	Stroke	T Slot	Total height	Dial graduation	PACKING LxWxH m/m	WEIGHT kgs	CODE NO.
VCT-407	100	180	130	100	115	50	50x80	3/8"	100	2.5mm/0.02	290x240x140	12	1007-001
VCT-514	150	350	250	300	206	208	156x170	3/8"	134	4mm/0.02	510x450x240	33.5	1007-002
VCT-820	200	500	300	400	250	290	200x250	3/8"	155	4mm/0.02	640x520x200	72	1007-003
VCT-1024	250	600	400	500	340	430	250x300	1/2"	210	4mm/0.02	790x680x310	141	1007-004

Precision Cross Table

ORDER NO.VCT-830 CODE NO.1007-010

A heavy, rugged slide in all kinds of positioning, milling, drilling micro-scope viewing and staging, adjustable bases for heavy loads, small jig boring, precision cut-off.



VCT-830

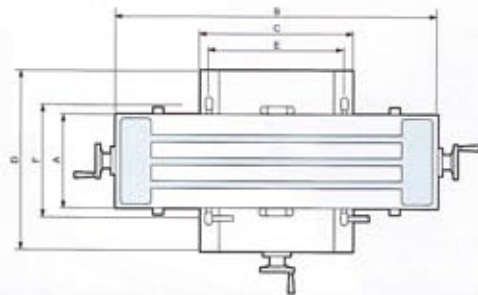

Specifications

Unit:mm

ORDER NO.	A	B	C	D	E	F	Stroke	T Slot	Total height	Dial graduation	PACKING LxWxH m/m	WEIGHT kgs	CODE NO.
VCT-830	210	730	345	405	305	230	190x350	16	185	2.5mm/0.05	991x584x292	100	1007-010

Cross Table

ORDER NO.VCT-512 CODE NO.1007-020



VCT-512

Table: 300x140mm
 Height: 115mm
 Travel: 200mm longitudinal.
 125mm transverse.
 Base: 225mm x 200mm oval with U slots for up to 16 bolts on 190 to 210 bolts circle.
 Dial Graduated: 0.03mm
 Net weight: 16.5kgs.
 Packing Volume of each unit: 430x265x155mm
 LIGHT DUTY ONLY