



# Mini Type Arm Type Air Tapping Unit

HIGH TORQUE HIGH EFFICIENCY EASY OPERATION



# VERTEX



## ACCESSORIES

- Air tapping spindle
- Parallel arm
- Table mounting column
- Air combination
- Choose any six safety clutch tapping adapters
- Radial jib
- Without stand plate
- Air pressure: 6~8 kgs/cm<sup>3</sup>
- VAT-08/12 series require: 5HP compressor
- VAT-16/20 series require: 10HP compressor

ORDER NO.	VAT-708	VAT-712	VAT-716
For Tap	M3~M8	M5~M12	M8~M16
	TC-312	TC-312	TC-820
Speed (rpm)	630/700	350/400	250
Weight (kgs)	13.2	13.1	17.3
Work Range	Rmax 700mm		
CODE NO.	3404-410	3404-411	3404-412



# Small Arm Type Air Tapping Unit

HIGH TORQUE HIGH EFFICIENCY EASY OPERATION

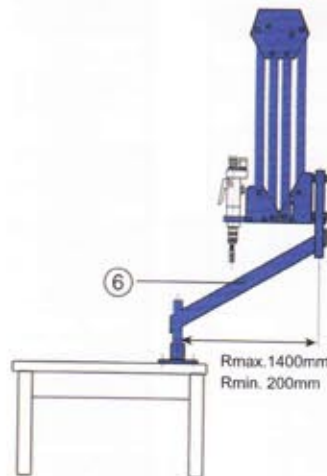

## ACCESSORIES

- Air tapping spindle
- Parallel arm
- Table mounting column
- Air combination
- Choose any six safety clutch tapping adapters
- Radial jib, increases arm reach by 500mm
- Without stand plate
- Air pressure: 6~8 kgs/cm<sup>3</sup>
- VAT-08/12 series require: 5HP compressor
- VAT-16/20 series require: 10HP compressor

ORDER NO.	VAT-1408	VAT-1412	VAT-1416
For Tap	M3~M8	M5~M12	M8~M16
	TC-312	TC-312	TC-820
Speed (rpm)	700	400	250
Weight (kgs)	18.2	18.2	24.6
Work Range	Rmax 1400mm		
	Rmin 200mm		
CODE NO.	3404-415	3404-416	3404-417