



HV-6, 8, 10, 12, 14, 16

Special Accessories (Details on page 2)



HV-4

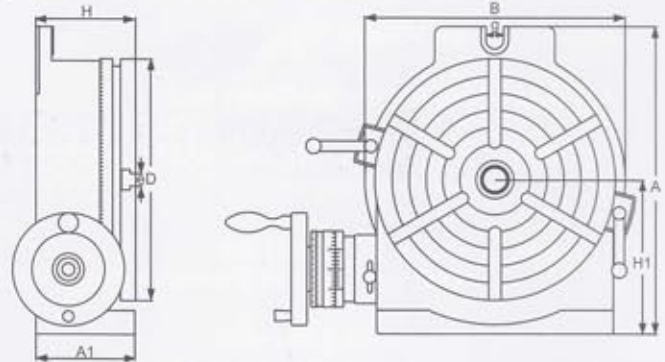

Specifications

Unit:mm/inches

| ORDER NO. | Table | | | Base dimension | | | Width of T-soft | | Bolt slots | The Load Capacity For Rotary Table | | Center sleeve | Gross Weight(kg) | | Meas. CFT | CODE NO. | |
|-----------|----------------|--------|-----|----------------|-----|-----|-----------------|------|------------|------------------------------------|------------|---------------|------------------|--------------------------|-----------|----------|------|
| | Outer diameter | Height | H | H1 | A | B | e | Type | | g | Horizontal | | Vertical | wooden case(W) Carton(C) | | | |
| | | | | | | | | | | | | | | N.W. | | | G.W. |
| HV-4 | 58 | 110 | 72 | 80 | 138 | 118 | 11 | ⊙ | 35 KGS | 18 KGS | MT-2 | 7KGS | 7.5KGS (C) | 0.3 | 1001-000 | | |
| HV-6 | 78 | 150 | 80 | 102 | 205 | 163 | 11 | ⊙ | 40 KGS | 20 KGS | MT-2 | 12.1KGS | 12.7KGS (C) | 0.4 | 1001-001 | | |
| HV-8 | 100 | 205 | 102 | 135 | 265 | 219 | 14 | ⊙ | 80 KGS | 40 KGS | MT-3 | 24.7KGS | 26.2KGS (C) | 0.8 | 1001-002 | | |
| HV-10 | 106 | 254 | 109 | 163 | 321 | 276 | 14 | ⊗ | 90 KGS | 50 KGS | MT-3 | 35.5KGS | 37.3KGS (C) | 2 | 1001-003 | | |
| HV-12 | 123 | 305 | 125 | 194 | 388 | 330 | 16 | ⊗ | 120 KGS | 60 KGS | MT-4 | 58.7KGS | 69.8KGS (W) | 2.6 | 1001-004 | | |
| HV-14 | 123 | 353 | 125 | 225 | 445 | 389 | 16 | ⊗ | 130 KGS | 70 KGS | MT-4 | 76.61KGS | 90.3KGS (W) | 3.2 | 1001-005 | | |
| HV-16 | 128 | 406 | 130 | 258 | 503 | 435 | 16 | ⊗ | 140 KGS | 70 KGS | MT-4 | 106.4KGS | 123.1KGS (W) | 4.2 | 1001-006 | | |

- Our Tables are made of high density Meehanite and use "HEIDENHAIN" electronic equipment to inspect angle to assure the excellent quality and durability.
- Use excellent machining center to process. Spindle end be applied accuracy bearing. Can be assured to keep very steady under load cutting.
- Worm is hardened and ground. The ratio is 90:1. The work table is graduated a full 360° so that one turn of the handle moves the table through 4°. Micro collar is graduated in steps of 1' min. And vernier scale makes settings down to 10 seconds possible.
- These Rotary Tables are popular for their excellent performance, practical design and reasonable cost. They are widely used for circular cutting work, angle setting, boring, spot-facing and similar work.
- Indexing accuracy of direct Indexing mechanism Maximum cumulative spacing error 1 minute.

3-Jaw Chuck For Rotary Table, Indexer

- Detail specification & Order NO. shown on page E6



ORDER NO.

- VSC-5A SUIT FOR BS-0 OR HV-6, VUT-6, VU-150
- VSC-6A SUIT FOR BS-1 OR HV-8, 10, VUT-6, VU-200
- VSC-7A, 8A SUIT FOR BS-2 OR HV-10, 12, 14, VUT-10, 12
- VSC-10A SUIT FOR HV-14, 16

Reversible type For indexer, The fixing hole is from front.



ORDER NO.

- VSK-6A SUIT FOR CS-6, CC-6
- VSK-8A SUIT FOR CS-8, CC-8
- VSK-12A SUIT FOR CC-12