



Standard Accessories



Special Accessories

The same as Rotary table
Please see page A2



CS-8 with VSK-8 3-JAW MASKING PLATE & FACE PLATE

This product combines the advantages of the Super Index with those of a worm-gear index. When mounted on a milling, boring or other machine tool it can carry out single-purpose indexing and indirect indexing using the worm-drive mechanism. Disengaging the worm drive the 24-notch master plate permits 2, 3, 4, 6, 8, 12 and 24 dividing in the same manner as the Simple Index. When the chuck is removed, the unit can be used as a horizontal and vertical type rotary table. The operating handle to rotary table worm gear reduction ratio is 1:90. The operating handle collar is graduated in one minute, and readings down to ten seconds can be set on the vernier.

- Super spacer index include 3 jaw chuck, 10"/250mm face plate, masking plates 2, 3, 4, 6, 8, 12.

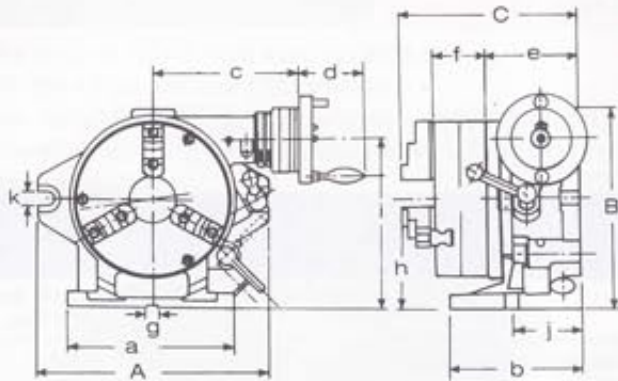

The state of CS-8 fitted with Face Plate & Dividing Plate

Specifications

ORDER NO.	Numbers of dividing	Chuck				Face plate		A	B	C	a
		Outer diameter	Inner jaw	Outer jaw	Inner dia	Outer dia	Thickness				
CS-6	2, 3, 4, 6, 8, 12, 24	167 VSK-6	4~42	10~156	44	203	50	250	235	221	220
CS-8		210 VSK-8	4~62	10~180	63	254	58	310	285	243	225

Unit:mm

ORDER NO.	b	c	d	e	f	g	h	i	j	k	Gross Weight kgs	Meas. CFT	CODE NO.
CS-6	150	184	82	112	66	16	123	186	80	18	(W)44.5	1.2	1001-060
CS-8	160	201	82	125	75	16	155	232	90	18	(W)71.5	3.1	1001-061

Unit:mm

(W)Wooden Case (C)Carton Case