

DIAL HEIGHT GAGE

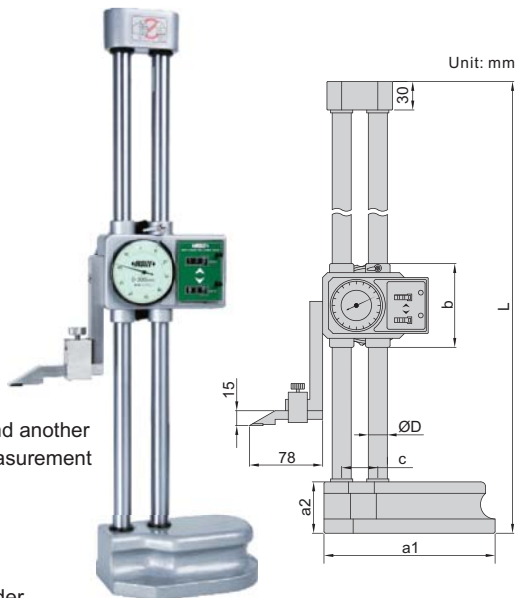

driving wheel

- Dial indicator graduation: 0.01mm
- One counter reads in the plus direction and another in the minus direction, so incremental measurement can be made in either direction
- Carbide tipped scriber
- Made of stainless steel (except the base)
- With driving wheel
- Optional accessory: dial test indicator holder (code 6293-6)



1351-300

(mm)

Code	Range	Accuracy	L	a1	a2	b	c	ØD
1351-300	0-300mm	±0.04mm	475	135	43	84	33	15
1351-450	0-450mm	±0.05mm	660	180	54	88	38	20
1351-600	0-600mm	±0.05mm	810	180	54	88	38	20

dial test indicator holder (optional)

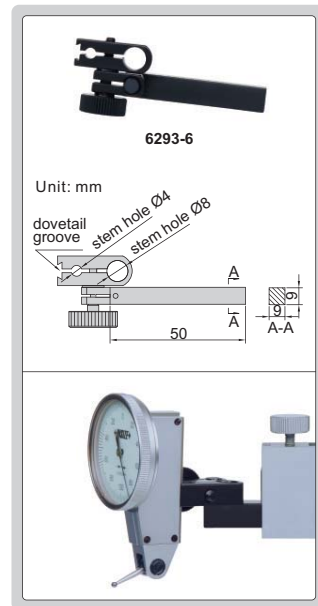

6293-6

Unit: mm

dovetail groove stem hole Ø4 stem hole Ø8

