

Dial Height Gage

SERIES 192 — with Digital Counter

FEATURES

- Easy and error-free reading with both up and down digital counters as well as a dial.
- Provided with a feed wheel for easy coarse feeding.
- Carbide-tipped scriber is provided.
- The counters and dial can be re-zeroed at any scriber position.

SPECIFICATIONS

Metric

Range	Order No.	Accuracy	Graduation	Mass (kg)
0 - 300mm	192-130	±0.03mm	0.01mm	4.2
0 - 450mm	192-131	±0.05mm	0.01mm	9.2
0 - 600mm	192-132	±0.05mm	0.01mm	9.8
0 - 1000mm	192-133	±0.07mm	0.01mm	17.0

Inch

Range	Order No.	Accuracy	Graduation	Mass (kg)
0 - 12"	192-150	±.0015"	.001"	4.2
0 - 18"	192-151	±.002"	.001"	9.2
0 - 24"	192-152	±.002"	.001"	9.8
0 - 40"	192-153	±.003"	.001"	17.0

DIMENSIONS

0 - 12" / 0 - 300mm, 0 - 18" / 0 - 450mm
0 - 24" / 0 - 600mm

0 - 40" / 0 - 1000mm

Unit: mm

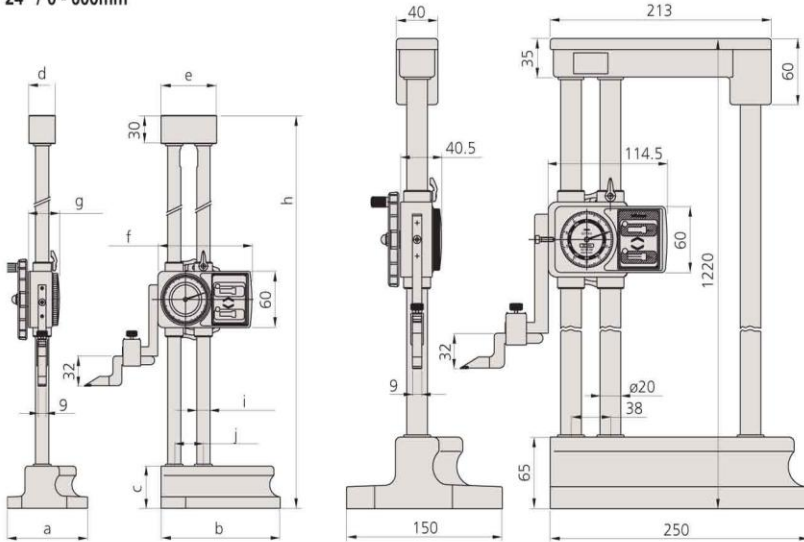

Range	a	b	c	d	e	f	g	h	i	j
0-12"/0-300mm	91	135	45	30	63	106.5	35.5	470	ø15	33
0-18"/0-450mm	120	180	54	32	70	114.5	40.5	645	ø20	38
0-24"/0-600mm	120	180	54	32	70	114.5	40.5	798	ø20	38



Technical Data

Dial reading: 0.01mm or .001"

Standard Scriber Provided

Metric models: Carbide-tipped scriber (**07GZA000**) and scriber clamp (**05GZA033**)
Inch/Metric models: Carbide-tipped scriber (**900258**) and scriber clamp (**901385**)

Dimension of scriber

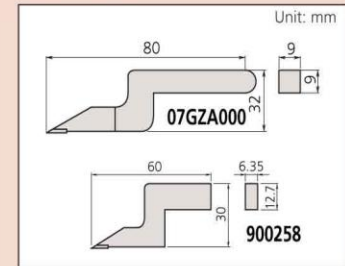

Optional Accessories

- 953638:** Holding bar for test indicator (length: 50mm)
- 900209:** Holding bar for test indicator (length: 100mm)
- 953639:** Holding bar for test indicator (length: 2")
- 900306:** Holding bar for test indicator (length: 4")
- 900321:** Swivel clamp used with holding bar (metric)
- 900322:** Swivel clamp used with holding bar (inch)

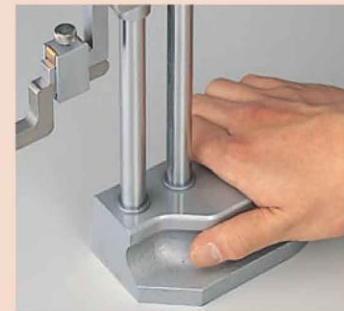

Comfortable grip base



Easy and secure clamping



Easy and error free reading